

## 20V N+P-Channel Enhancement Mode MOSFET

### Description

The AP4G02LI uses advanced trench technology to provide excellent  $R_{DS(ON)}$ , low gate charge and operation with gate voltages as low as 2.5V. This device is suitable for use as a Battery protection or in other Switching application.

### General Features

$V_{DS} = 20V$   $I_D = 4.5A$

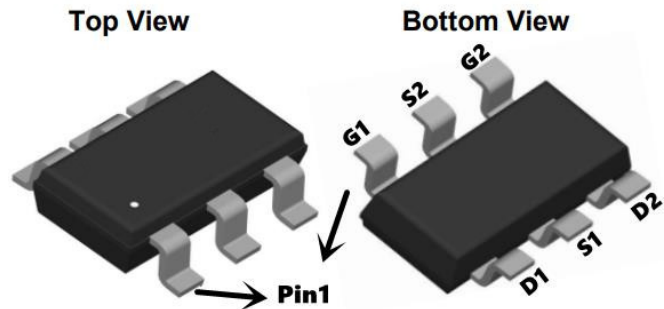
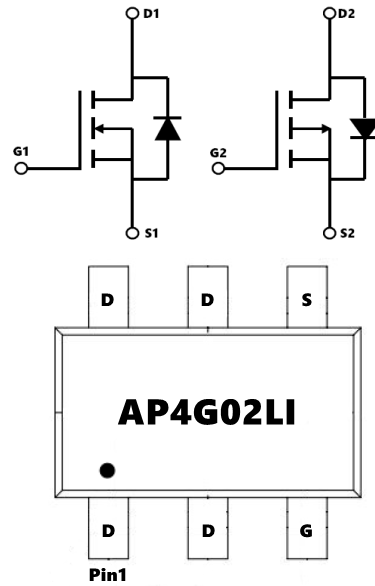
$R_{DS(ON)} < 35m\Omega$  @  $V_{GS}=4.5V$  (Type: **28mΩ**)

$V_{DS} = -20V$   $I_D = -3.8A$

$R_{DS(ON)} < 80m\Omega$  @  $V_{GS}=-4.5V$  (Type: **55mΩ**)

### Application

BLDC



### Package Marking and Ordering Information

Product ID	Pack	Marking	Qty(PCS)
AP4G02LI	SOT23-6L	AP4G02LI	3000

### Absolute Maximum Ratings ( $T_C=25^\circ\text{C}$ unless otherwise noted)

Symbol	Parameter	N-Ch	P-Ch	Units
$V_{DS}$	Drain-Source Voltage	20	-20	V
$V_{GS}$	Gate-Source Voltage	$\pm 20$	$\pm 20$	V
$I_D @ T_A=25^\circ\text{C}$	Continuous Drain Current, $V_{GS} @ 10V^1$	4.5	-3.8	A
$I_D @ T_A=70^\circ\text{C}$	Continuous Drain Current, $V_{GS} @ 10V^1$	3.0	-2.5	A
$I_{DM}$	Pulsed Drain Current <sup>2</sup>	52	-40	A
EAS	Single Pulse Avalanche Energy <sup>3</sup>	12	18	mJ
$P_D @ T_A=25^\circ\text{C}$	Total Power Dissipation <sup>4</sup>	1.5	1.5	W
$T_{STG}$	Storage Temperature Range	-55 to 150		$^\circ\text{C}$
$T_J$	Operating Junction Temperature Range	-55 to 150		$^\circ\text{C}$
$R_{\theta JA}$	Thermal Resistance Junction-Ambient <sup>1</sup>	105		$^\circ\text{C/W}$
$R_{\theta JC}$	Thermal Resistance Junction-Case <sup>1</sup>	50		$^\circ\text{C/W}$



**20V N+P-Channel Enhancement Mode MOSFET**
**N-Electrical Characteristics (T<sub>J</sub>=25°C, unless otherwise noted)**

Symbol	Parameter	Conditions	Min.	Typ.	Max.	Unit
BV <sub>DSS</sub>	Drain-Source Breakdown Voltage	V <sub>GS</sub> =0V, I <sub>D</sub> =250uA	20	22	---	V
R <sub>DS(ON)</sub>	Static Drain-Source On-Resistance <sup>2</sup>	V <sub>GS</sub> =4.5V, I <sub>D</sub> =3A	---	28	35	mΩ
		V <sub>GS</sub> =2.5V, I <sub>D</sub> =2A	---	32	40	
V <sub>GS(th)</sub>	Gate Threshold Voltage	V <sub>GS</sub> =V <sub>DS</sub> , I <sub>D</sub> =250uA	0.5	0.75	1.2	V
I <sub>DSS</sub>	Drain-Source Leakage Current	V <sub>DS</sub> =16V, V <sub>GS</sub> =0V, T <sub>J</sub> =25°C	---	---	1	uA
		V <sub>DS</sub> =16V, V <sub>GS</sub> =0V, T <sub>J</sub> =55°C	---	---	5	
I <sub>GSS</sub>	Gate-Source Leakage Current	V <sub>GS</sub> =±12V, V <sub>DS</sub> =0V	---	---	±100	nA
g <sub>fs</sub>	Forward Transconductance	V <sub>DS</sub> =5V, I <sub>D</sub> =3A	---	10.5	---	S
Q <sub>g</sub>	Total Gate Charge (4.5V)	V <sub>DS</sub> =15V, V <sub>GS</sub> =4.5V, I <sub>D</sub> =3A	---	4.6	---	nC
Q <sub>gs</sub>	Gate-Source Charge		---	0.7	---	
Q <sub>gd</sub>	Gate-Drain Charge		---	1.5	---	
T <sub>d(on)</sub>	Turn-On Delay Time	V <sub>DD</sub> =10V, V <sub>GS</sub> =4.5V, R <sub>G</sub> =3.3Ω, I <sub>D</sub> =3A	---	1.6	---	ns
T <sub>r</sub>	Rise Time		---	42	---	
T <sub>d(off)</sub>	Turn-Off Delay Time		---	14	---	
T <sub>f</sub>	Fall Time		---	7	---	
C <sub>iss</sub>	Input Capacitance	V <sub>DS</sub> =15V, V <sub>GS</sub> =0V, f=1MHz	---	310	---	pF
C <sub>oss</sub>	Output Capacitance		---	49	---	
C <sub>rss</sub>	Reverse Transfer Capacitance		---	35	---	
I <sub>S</sub>	Continuous Source Current <sup>1,4</sup>	V <sub>G</sub> =V <sub>D</sub> =0V, Force Current	---	---	3.6	A
V <sub>SD</sub>	Diode Forward Voltage <sup>2</sup>	V <sub>GS</sub> =0V, I <sub>S</sub> =1A, T <sub>J</sub> =25°C	---	---	1.2	V

**Note :**

- 1、The data tested by surface mounted on a 1 inch<sup>2</sup>FR-4 board with 2OZ copper.
- 2、The data tested by pulsed, pulse width ≤ 300us, duty cycle ≤ 2%
- 3、The power dissipation is limited by 150°C junction temperature
- 4、The data is theoretically the same as I<sub>D</sub> and I<sub>DM</sub>, in real applications, should be limited by total power dissipation.

**20V N+P-Channel Enhancement Mode MOSFET**
**P-Electrical Characteristics (T<sub>J</sub>=25°C, unless otherwise noted)**

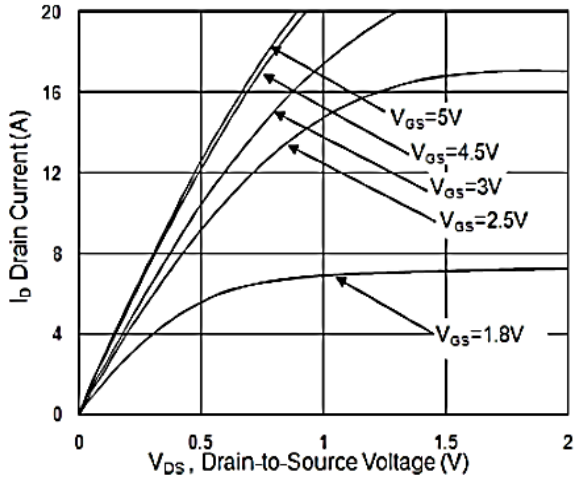
Symbol	Parameter	Conditions	Min.	Typ.	Max.	Unit
BV <sub>DSS</sub>	Drain-Source Breakdown Voltage	V <sub>GS</sub> =0V, I <sub>D</sub> =-250uA	-20	-22	---	V
R <sub>DS(ON)</sub>	Static Drain-Source On-Resistance <sup>2</sup>	V <sub>GS</sub> =-4.5V, I <sub>D</sub> =-3A	---	55	80	mΩ
		V <sub>GS</sub> =-2.5V, I <sub>D</sub> =-2A	---	75	100	
V <sub>GS(th)</sub>	Gate Threshold Voltage	V <sub>GS</sub> =V <sub>DS</sub> , I <sub>D</sub> =-250uA	-0.45	-0.6	-1.0	V
I <sub>DSS</sub>	Drain-Source Leakage Current	V <sub>DS</sub> =-20V, V <sub>GS</sub> =0V, T <sub>J</sub> =25°C	---	---	-1	uA
		V <sub>DS</sub> =-20V, V <sub>GS</sub> =0V, T <sub>J</sub> =55°C	---	---	-5	
I <sub>GSS</sub>	Gate-Source Leakage Current	V <sub>GS</sub> =±12V, V <sub>DS</sub> =0V	---	---	±100	nA
g <sub>fs</sub>	Forward Transconductance	V <sub>DS</sub> =-5V, I <sub>D</sub> =-3A	---	12.2	---	S
Q <sub>g</sub>	Total Gate Charge (-4.5V)	V <sub>DS</sub> =-15V, V <sub>GS</sub> =-4.5V, I <sub>D</sub> =-3A	---	10.1	---	nC
Q <sub>gs</sub>	Gate-Source Charge		---	1.21	---	
Q <sub>gd</sub>	Gate-Drain Charge		---	2.46	---	
T <sub>d(on)</sub>	Turn-On Delay Time	V <sub>DD</sub> =-10V, V <sub>GS</sub> =-4.5V, R <sub>G</sub> =3.3Ω, I <sub>D</sub> =-3A	---	5.6	---	ns
T <sub>r</sub>	Rise Time		---	32.2	---	
T <sub>d(off)</sub>	Turn-Off Delay Time		---	45.6	---	
T <sub>f</sub>	Fall Time		---	29.2	---	
C <sub>iss</sub>	Input Capacitance	V <sub>DS</sub> =-15V, V <sub>GS</sub> =0V, f=1MHz	---	677	---	pF
C <sub>oss</sub>	Output Capacitance		---	82	---	
C <sub>rss</sub>	Reverse Transfer Capacitance		---	73	---	
I <sub>s</sub>	Continuous Source Current <sup>1,4</sup>	V <sub>G</sub> =V <sub>D</sub> =0V, Force Current	---	---	-3	A
V <sub>SD</sub>	Diode Forward Voltage <sup>2</sup>	V <sub>GS</sub> =0V, I <sub>S</sub> =-1A, T <sub>J</sub> =25°C	---	---	-1	V

**Note :**

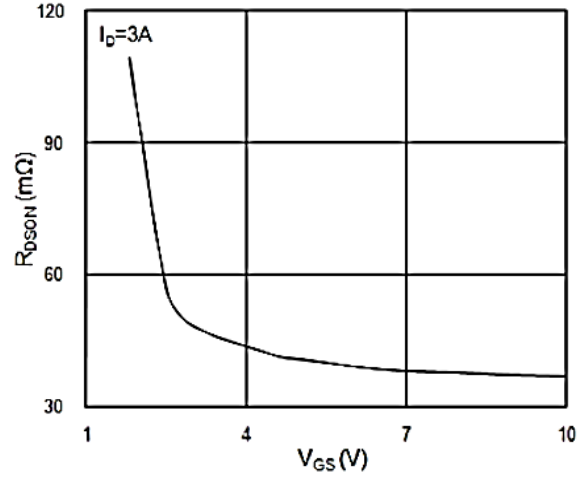
- 1、 The data tested by surface mounted on a 1 inch<sup>2</sup> FR-4 board with 2OZ copper.
- 2、 The data tested by pulsed , pulse width ≦ 300us , duty cycle ≦ 2%
- 3、 The power dissipation is limited by 150°C junction temperature
- 4、 The data is theoretically the same as I<sub>D</sub> and I<sub>DM</sub> , in real applications , should be limited by total power dissipation.

**20V N+P-Channel Enhancement Mode MOSFET**

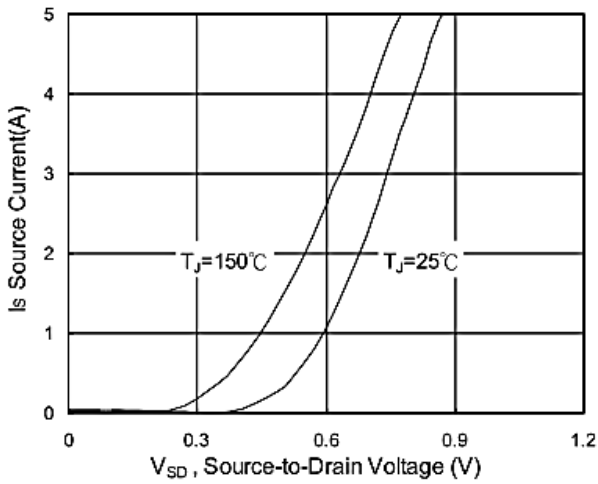
**N-Channel Typical Characteristics**



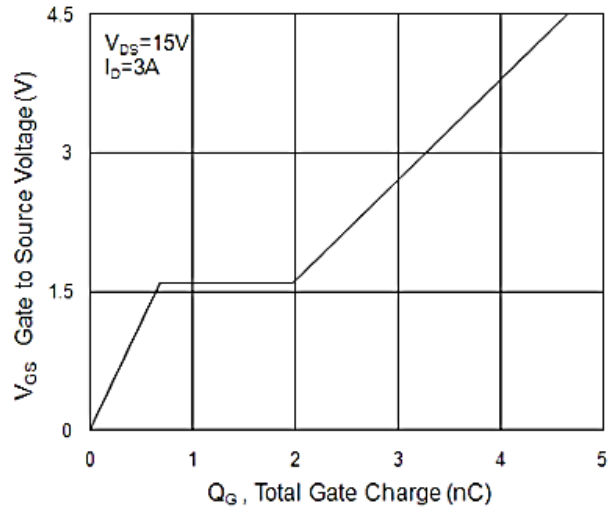
**Fig.1 Typical Output Characteristics**



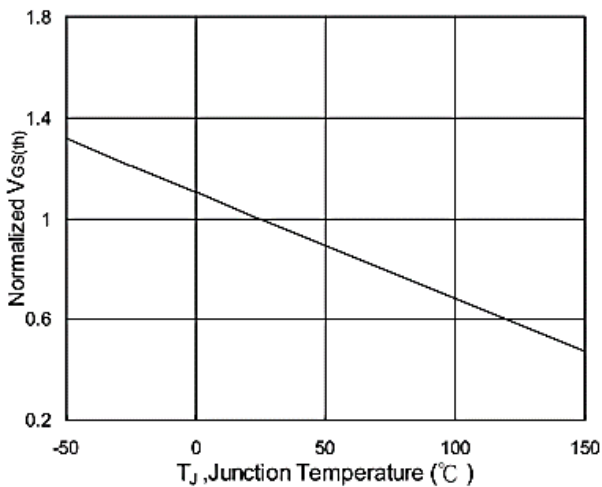
**Fig.2 On-Resistance vs. G-S Voltage**



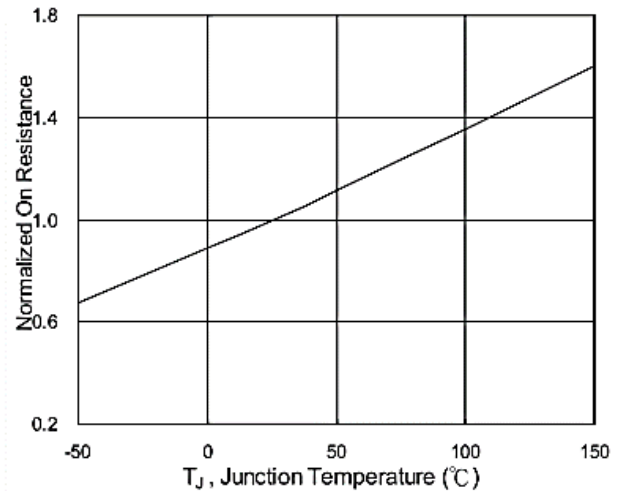
**Fig.3 Source Drain Forward Characteristics**



**Fig.4 Gate-Charge Characteristics**

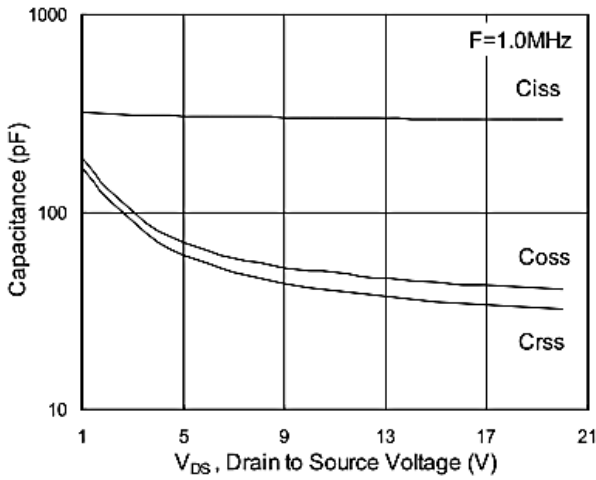


**Fig.5 Normalized  $V_{GS(th)}$  vs.  $T_J$**

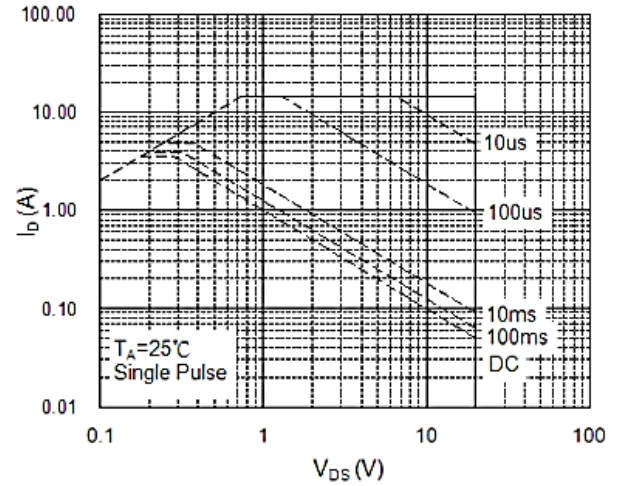


**Fig.6 Normalized  $R_{DS(on)}$  vs.  $T_J$**

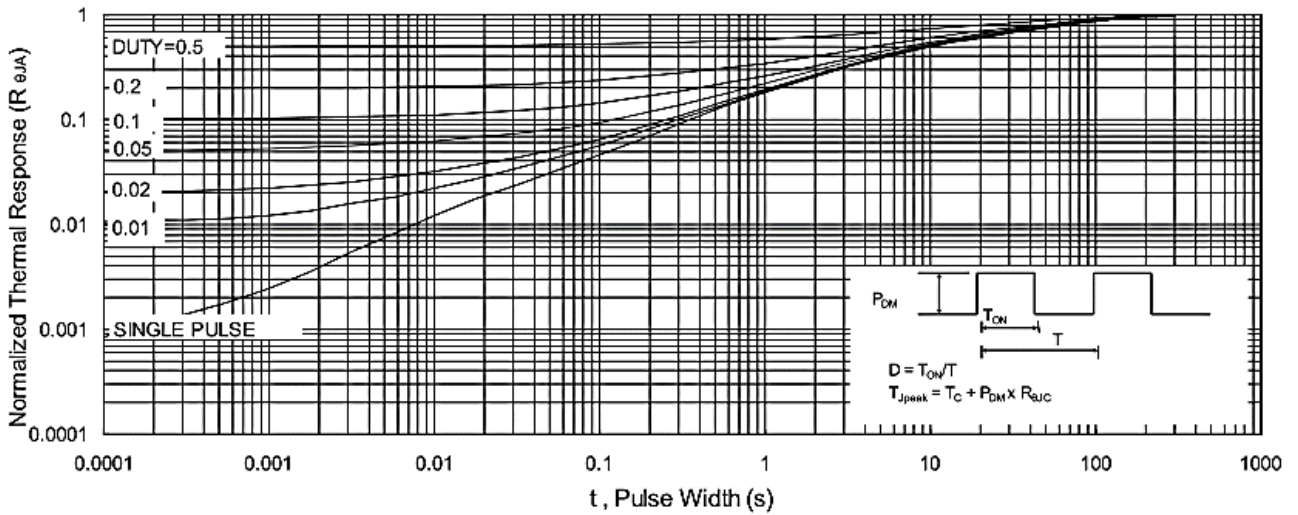
**20V N+P-Channel Enhancement Mode MOSFET**



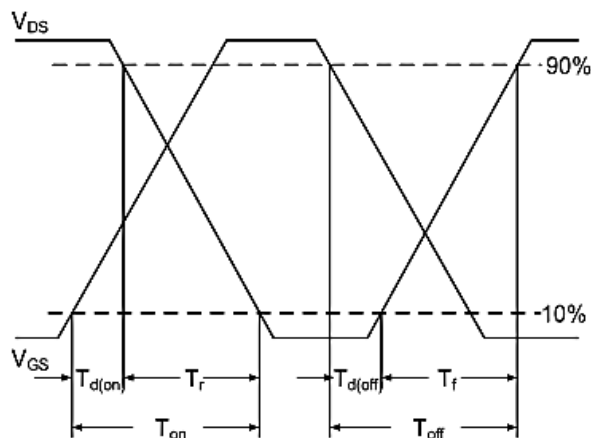
**Fig.7 Capacitance**



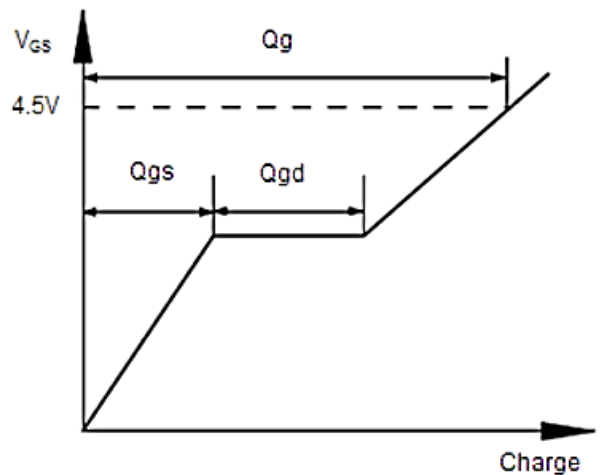
**Fig.8 Safe Operating Area**



**Fig.9 Normalized Maximum Transient Thermal Impedance**



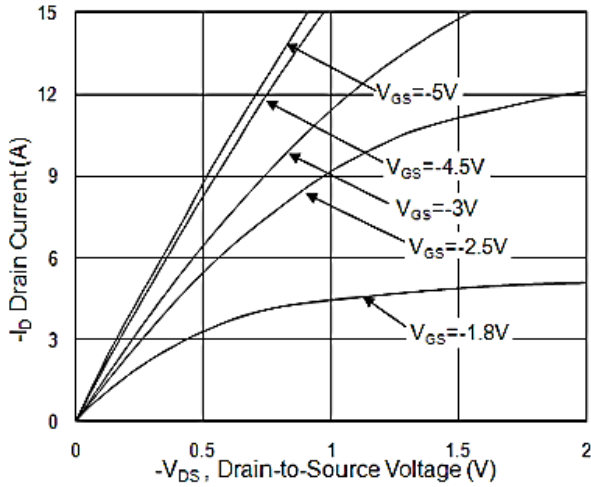
**Fig.10 Switching Time Waveform**



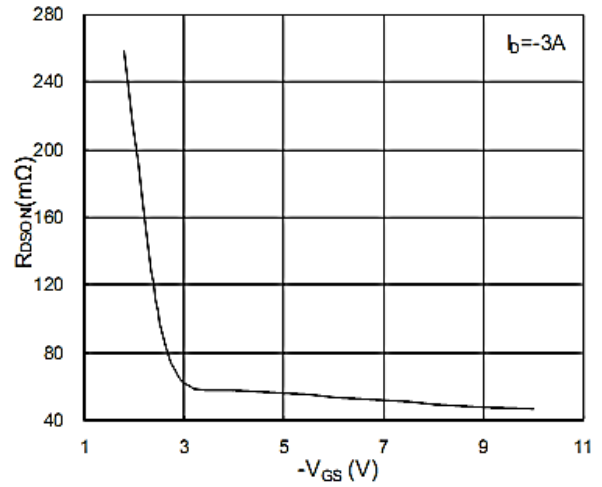
**Fig.11 Gate Charge Waveform**

**20V N+P-Channel Enhancement Mode MOSFET**

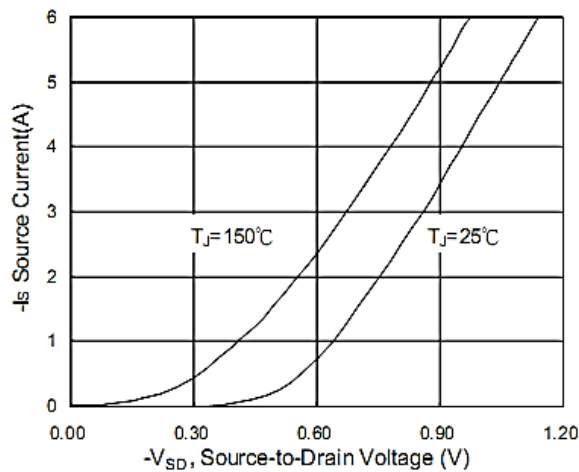
**P-Channel Typical Characteristics**



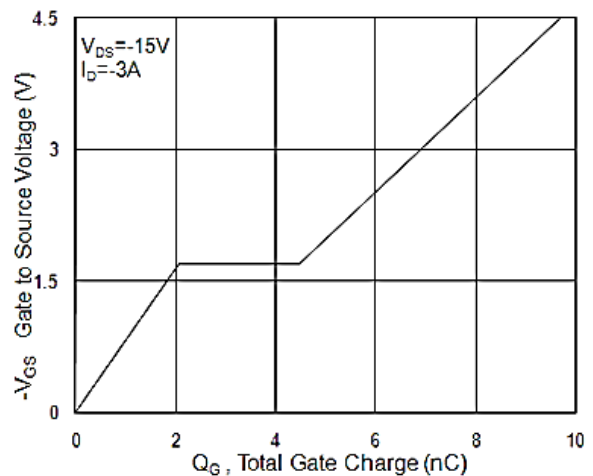
**Fig.1 Typical Output Characteristics**



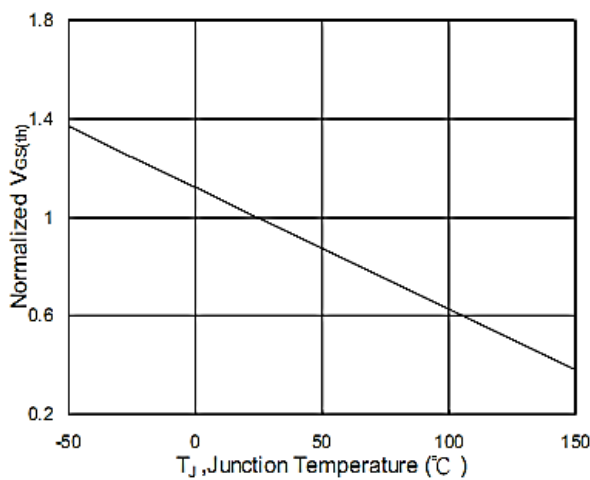
**Fig.2 On-Resistance vs. Gate-Source**



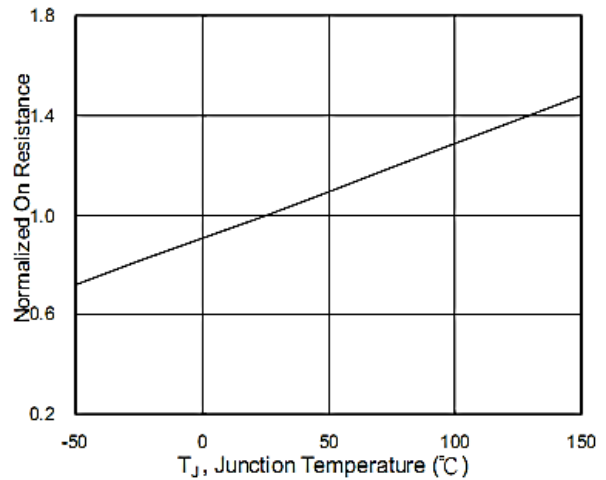
**Fig.3 Forward Characteristics Of Reverse**



**Fig.4 Gate-Charge Characteristics**

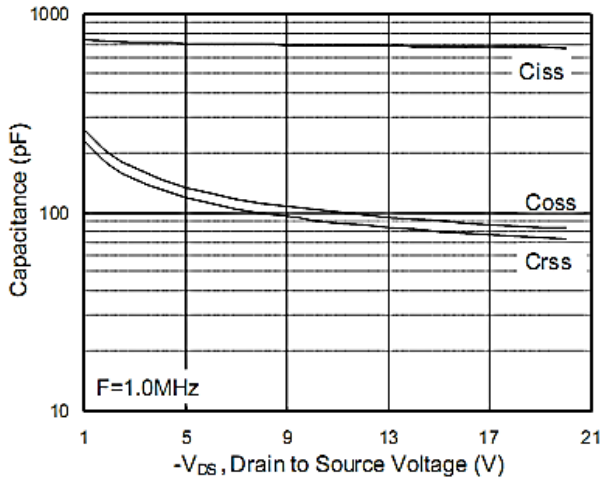


**Fig.5 Normalized  $V_{GS(th)}$  vs.  $T_J$**

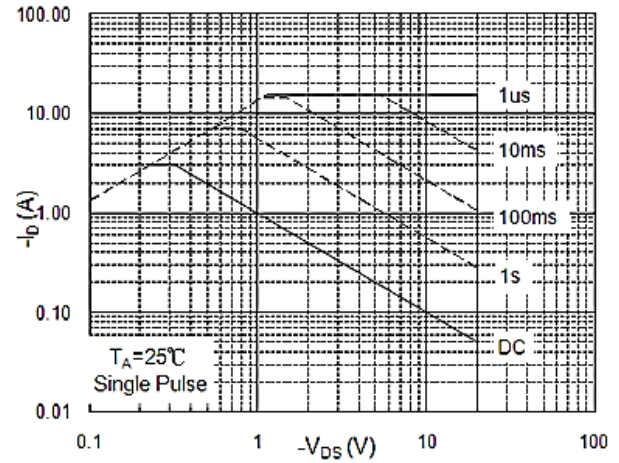


**Fig.6 Normalized  $R_{DS(on)}$  vs.  $T_J$**

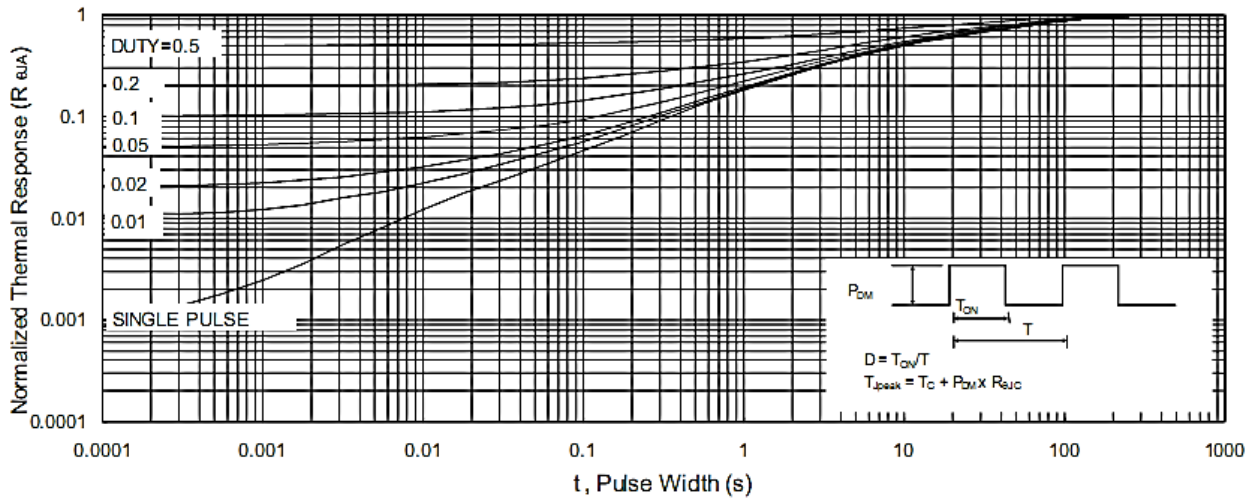
**20V N+P-Channel Enhancement Mode MOSFET**



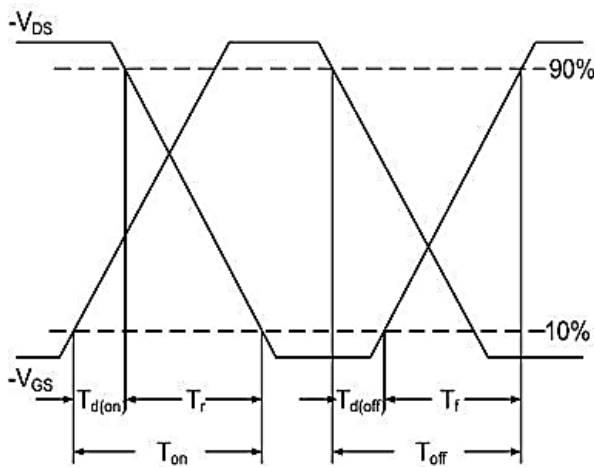
**Fig.7 Capacitance**



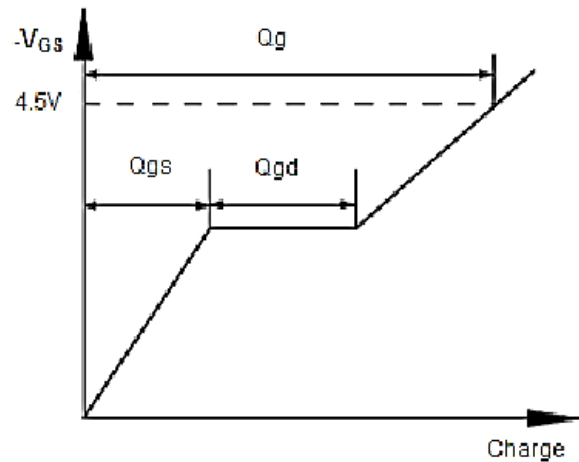
**Fig.8 Safe Operating Area**



**Fig.9 Normalized Maximum Transient Thermal Impedance**

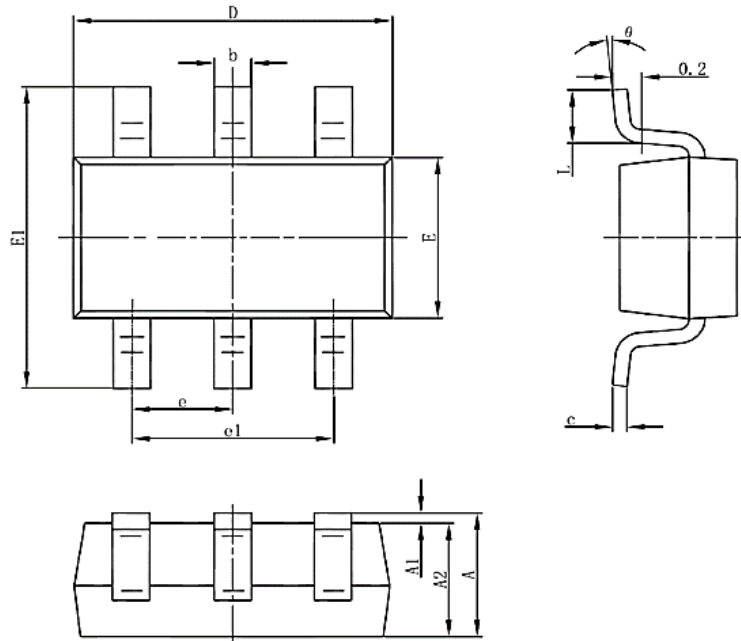


**Fig.10 Switching Time Waveform**



**Fig.11 Gate Charge Waveform**



**20V N+P-Channel Enhancement Mode MOSFET**
**Package Mechanical Data-SOT23-6-Double**


Symbol	Dimensions In Millimeters		Dimensions In Inches	
	Min.	Max.	Min.	Max.
A	1.050	1.250	0.041	0.049
A1	0.000	0.100	0.000	0.004
A2	1.050	1.150	0.041	0.045
b	0.300	0.500	0.012	0.020
C	0.100	0.200	0.004	0.008
D	2.820	3.020	0.111	0.119
E	1.500	1.700	0.059	0.067
E1	2.650	2.950	0.104	0.116
e	0.950 (BSC)		0.037(BSC)	
e1	1.800	2.000	0.071	0.079
L	0.300	0.600	0.012	0.024
θ	0	8	0	8